

# New Push-Pull Tube Amplifiers

By Menno van der Veen

## Introduction

With landmark design work such as the author presents here, the future of the tube amps, which reached their peak around the middle of this century, appears quite strong as we head into a new millennium.

The first tube amplifiers were constructed with triodes, directly coupled to high impedance loudspeakers, with interstage transformers, but without output transformers. The demand for greater output power led to paralleled triodes and triodes in push-pull configurations with balanced output transformers. Based on the rejection of amplified radio frequencies at the control grid, the screen grid was invented, resulting in tetrode tubes and later pentode tubes.

The rapidly advancing tube technology made possible the high-power triodes and pentodes that resulted in amplifiers with greater output power. In the 1940s great inventions were made by Hafler and Keroes, Peter Walker and McIntosh, and many others, resulting in high advanced amplifiers with huge output power.

Those days saw the invention of screen-grid feedback (ultralinear configuration) and cathode feedback (as still used in the famous amplifiers of Audio Research). McIntosh especially deserves a place of honor with his famous unity-coupled amplifiers, in which he used a combination of cathode- and screen-grid feedback.

## Standardized Designs

After the '50s, the growth of new ideas in tube-amplifier circuitry declined, and standardized designs became generally accepted, such as the Lafayette 2 x EL84 (6BQ8) push-pull power amplifiers in pentode mode with a rather large amount of overall negative feedback and a 12W power bandwidth from 20Hz-30kHz. Such amplifiers were found in many a music lover's living room, and they were typical for music enjoyment with 33.3 rpm records on a turntable with a piezo pick-up element.

Reprinted from *Glass Audio 3/99*

TABLE 1  
FIGURE 1 CIRCUITS.

Amp	1	2	3	4	5	6	7	8	Unit
Power	74	5.5	27	-	80	63	49	27	Watt
DF	0.051	0.315	0.948	-	0.646	0.953	1.61	2.58	8/Z <sub>out</sub>

TABLE 2  
FIGURE 1 AMPLIFIER-OUTPUT CONNECTIONS TO THE OPT WIRES.

CIRCUIT	1	2	3	4	5	6	7	8
<b>AMPLIFIER OUTPUTS</b>								
A1	5	5	5	-	5	5	5	5
SG1	V1	4	5	-	2	V1	4	5
K1	7	7	7	-	6	6	6	6
K2	8	8	8	-	9	9	9	9
SG2	V1	2	1	-	4	V1	2	1
A2	1	1	1	-	1	1	1	1

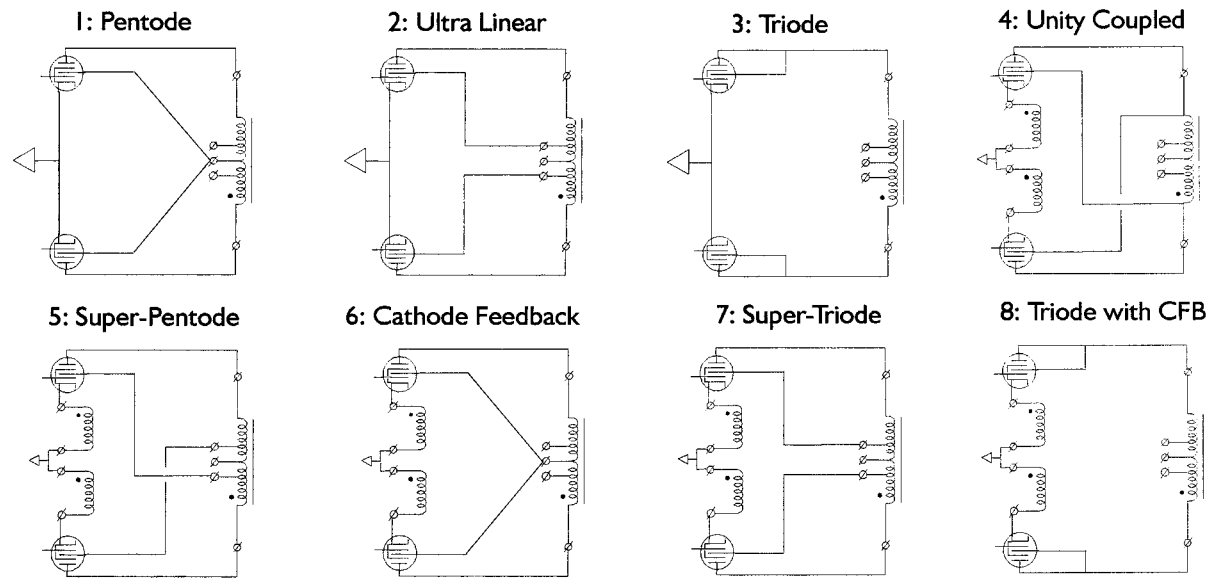

FIGURE 1: Eight push-pull amplifier circuits with combinations of negative and positive feedback.

Then the invention of the transistor and its rapidly growing development in the '60s nearly strangled new tube ideas. The output-transformerless (OTL) amplifier was introduced and manufactured in very limited numbers for high-end music lovers, although this new technique, like many other excellent ideas, did not become a standard.

Nowadays the tube amplifier, in whatever configuration, is considered to be a musical instrument *par excellence*. The triode amplifier in single-ended (SE) configuration is even the extreme of high-quality amplification, greatly surpassing any transistor amplifier design.

I intend this article to be a logical consequence of the fine inventions of the '50s and I continue those lines of thought by bringing some new ideas at the end of the millennium.

G-1328-1

## Old New Thinking

Figure 1 shows several push-pull tube amplifiers (only the power tubes and the output transformer's primary winding). The anodes are connected to the primary winding, the cathodes to ground (circuits 1, 2, and 3), and the middle of the primary to the high-voltage supply. The drive circuitry of the control grids is not shown—I assume perfect driving.

When the screen grids are connected to the high-voltage supply you have a standard push-pull pentode amplifier (circuit 1). With the screen grids connected to taps on the primaries (at 33 or 40% in general) the amplifier is in an ultralinear configuration (circuit 2). And when you connect the screen grids with their anodes, the tubes behave like triodes, and you have a push-pull triode amplifier (circuit 3).

Going from the pentode through ultralinear to triode mode, the output power decreases, the bandwidth and the damping factor increase, and the distortion diminishes (assuming correct setting of the tubes' quiescent currents). These first three circuits are standard practice nowadays and give excellent results, even when compared to SE designs.

The essential line of thinking in these first three amplifiers is just a matter of applying local negative feedback between the power tubes and the output transformer. The more negative feedback at the screen grids, the better the qualities of the amplifier. This is local feedback in its purest form.

However, going from pentode to triode, better qualities are gained at the cost of output power. Is there not a circuit or a line of thinking that maintains output power while raising the damping factor as well as the frequency range and linearity? Yes, there is. In circuits 1, 2, and 3, only the screen grids are used for negative feedback. Why not use the cathodes (or the control grids) of the power tubes as well? McIntosh has shown that this line of thinking is successful.

## Further Configurations

In circuits 4–8 of Fig. 1, the cathodes are connected to separate cathode feedback windings, the phase connections of which are such that the cathodes receive negative feedback. The only difference in amplifier circuits 4–8 is the way the screen grids are connected to the output transformer.

In circuit 5, the screen grids are connected to taps on the opposite halves of the primary winding, resulting in positive feedback at the screen grids. With careful balancing of this positive grid feedback and the negative cathode feedback, you can construct an ultra-high-power amplifier with a large damping factor. This newly invented amplifier is called the Super-Pentode®. (More details later.)

Circuit 6 shows only cathode feedback, and the advantages of this circuit are known worldwide. Circuit 7 uses negative cathode feedback combined with negative screen-grid feedback, resulting in great output power with linearity and damping factor far surpassing a standard push-pull triode circuit. This circuit, also newly invented, is called the Super-Triode® amplifier.

Last of all, circuit 8 shows the combination of negative cathode feedback and 100% negative screen-grid feedback, providing push-pull triode behavior with less output power but extremely good linearity and damping factor.

I have not discussed circuit 4 because it is stable only under the special conditions as set by McIntosh, with a local feedback ratio equal to 1. Before further discussing the Super-Pentode's and Super-Triode's qualities and applications, I will present a few theoretical thoughts and measurement results.

## Theories and Results

This article deals with the practical side of making new amplifiers, using the new inventions and new toroidal output-transformer technologies. However, new ideas are always founded on concepts and theories. I don't wish to deal with those theories now, but refer you to the extensive audio-engineering

literature, where all the theoretical concepts are defined and discussed at length. From these publications I now abstract only three fundamental issues: output power, pentodes versus tetrodes, and the damping factor.

First, consider the available output power per amplifier circuit. I calculated and measured these powers, and the results are shown in Table 1 under the conditions of a specialist VDV-2100-CFB/H toroidal output transformer, a high supply voltage of 450V (at maximum power output), and a quiescent current of 45mA per EL34 pentode tube. Especially striking is the large output-power capability of the Super-Pentode (circuit 5), delivering up to an unusual 80W with only two EL34 tubes.

Second, the use of real pentodes such as the EL34 is essential for achieving the large output powers as shown in Table 1. When repeating these tests with beam power tetrodes, such as the 6V650C, the maximum power in circuits 1, 5, 6, and 7 stays close to 60W. Do pentodes behave differently from beam power tetrodes? Yes. Real pentodes allow for a shifting of the tube-characteristic lines to the left when the screen-grid feedback changes, resulting in greater output powers. Beam power tetrodes do not allow for that, so they don't show the remarkable 80W power as you find with the EL34 tubes in circuit 5. However, beam power tetrodes have other special advantages I will discuss later.

Third, at the secondary side of the special VDV-2100-CFB/H output transformer, I calculated the damping factor (DF). By this I mean the loudspeaker impedance (standardized for now to 8Ω) divided by the output impedance of the amplifier circuits, including the internal resistances in the output transformer. In Table 1 circuits 1–3 show standard results. The standard push-pull pentode circuit (1) acts almost like a current source, with a very large output impedance and consequently a very small damping factor.

Now compare circuits 5, 6, and 7 with circuit 1, and you see that the combination of screen-

grid and cathode feedback gives a much larger damping factor (and consequently a much better-controlled bass response), without applying nasty overall negative feedback from the amplifier's output to input.

I conclude that especially the new circuits 5 and 7 and the known circuit 6 offer large power capabilities combined with large damping factors and, as I will discuss later, a high degree of linearity. It is now up to you to take advantage of these new circuits by building and testing these amps yourself. I will now explain how to construct them.

## Building Eight Amps

Fortunately, it is very simple to build these amplifier circuits when good tube circuits and good output transformers are available. In fact, I did all this research to design a special series of new toroidal output transformers, the so-called "specialist" series. *Figure 2* shows the schematic of the tube amplifier

I used for all the tests. *Figure 3* shows the power supply (the power supply transformer for 120V mains is available from Plitron, #754709). *Figure 4* gives the numbering and the colors of the wires of the toroidal output transformer and their positions on this round device.

*Table 2* shows how to wire the OPT to the tube amplifier to obtain all the circuits shown in *Fig. 1*. In each amplifier, anode A1 of the upper tube B3 is connected to the upper tag 5 (yellow) of the output transformer. This is indicated in the first row of *Table 2*. In each amp, anode A2 of the lower tube B4 is connected to the lower tag 1 (green) of the output transformer. This is indicated in the lowest row of *Table 2*.

Now, for amplifiers 1, 2, and 3, the cathode K1 is connected to output tag 7 and through resistor R21 (10Ω) to ground. Cathode K2 is connected to tag 8 and through resistor R22 (10Ω) to ground. (See the third and fourth rows in *Table 2*.) Resistors R21 and R22 enable easy measurement of the quiescent current.

In amps 5–8, the cathode feedback windings are used. There cathode K1 is connected to tag 6 (orange) and cathode K2 to tag 9 (violet). Now the two cathode windings are used, while resistors R21 and R22 function as well, enabling you to measure the quiescent currents. All the cathode winding tags are at the 6 o'clock position at the bottom of the OPT (*Fig. 4*).

As for the screen grids, in amplifier 1 the screen grid SG1 of the upper tube is connected directly to the high-voltage power supply V1, as is the other lower screen grid, SG2. For amplifier 2, an ultralinear tap is needed, indicated by SG1 = tag 4 (violet at 12 o'clock) and SG2 = tag 2 (brown at 12 o'clock). Compare this to amplifier 7. The only difference is that amplifier 7 uses cathode feedback as well. Amplifier 3 needs a triode connection, meaning that A1 = SG1 = tag 5, and A2 = SG2 = tag 1. (Compare with amplifier 8, where extra cathode feedback is used.) And so on.

## The Amplifier Circuit

A short explanation of the circuit in *Fig. 2* might support the building of this special amplifier. Tube B1a delivers preamplification, and B1b functions as a phase splitter. In the anode section of the phase splitter, a variable resistor P1 allows trimming the equality of the output voltages (at C1 and C2) of the phase splitter. There follows an extra amplifier stage (B2) with large output voltage and driving capability. The quiescent currents of the power tubes B3 and B4 (EL34 or SV6550C) are set with trimpots P2 and P3. The amount of the quiescent current is measured over R21 and R22 (*Fig. 4*).

I'll give an example of how to define the quiescent current. Suppose you use two EL34 power tubes. The high voltage supply will be somewhere from 460–470V, and the maximum anode dissipation of an EL34 is 25W. Then the maximum allowable quiescent current per tube is  $25/470 = 53\text{mA}$ . A safe quiescent current value is then 45mA per

tube. This current flows through R21 (tube B3) and R22 (tube B4) (*Fig. 4*). Therefore a voltage of  $0.045 \times 10 = 0.45\text{V}$  should appear over R21 and R22. You can easily measure this voltage with a DC voltmeter while tuning the quiescent current with P2 and P3 until this 0.45V is measured over R21 and R22. I advise use of a ten-turn trimpot version for P2 and P3 for easy adjustment.

The only thing that changes if you use this amplifier with SV6550C is that you can set the quiescent current differently. The maximum anode dissipation of the SV6550C is 35W, allowing for a maximum quiescent current of  $35/470 = 75\text{mA}$  per tube. A value of 45mA is a safe value, but the maximum of 75mA is strongly preferred.

And why should you consider choosing such a large quiescent current and consequently shortening the tube's life? The simple reason is that the sound quality becomes amazingly clean and stable when compared to lower quiescent-current settings. The shorter tube life (about 1600–2000 hours compared to 6000 hours at 45mA) might be a very acceptable sacrifice. The choice is up to you.

You need to deal with one other special choice. In *Fig. 2* look at C1 and R7 (the same for C2 and R9). These components form a high-pass filter section with a -3dB corner frequency at 10.6Hz. This combines very well with the low-frequency power behavior of the output transformer, preventing it from being overloaded. But some might argue that this develops an extra-large low-frequency group delay. Correct, and if you are sensitive to that, you might consider giving R7 and R9 the value of 470kΩ, lowering the -3dB corner frequency to 2.3Hz. In that case, however, you certainly should not attempt to apply extra overall negative feedback from the speakers' output through a feedback resistor to the feedback input at the top of R2. Then surely "motorboating" (low-frequency oscillation) will occur. In that case, use the values as given in *Fig. 2*.



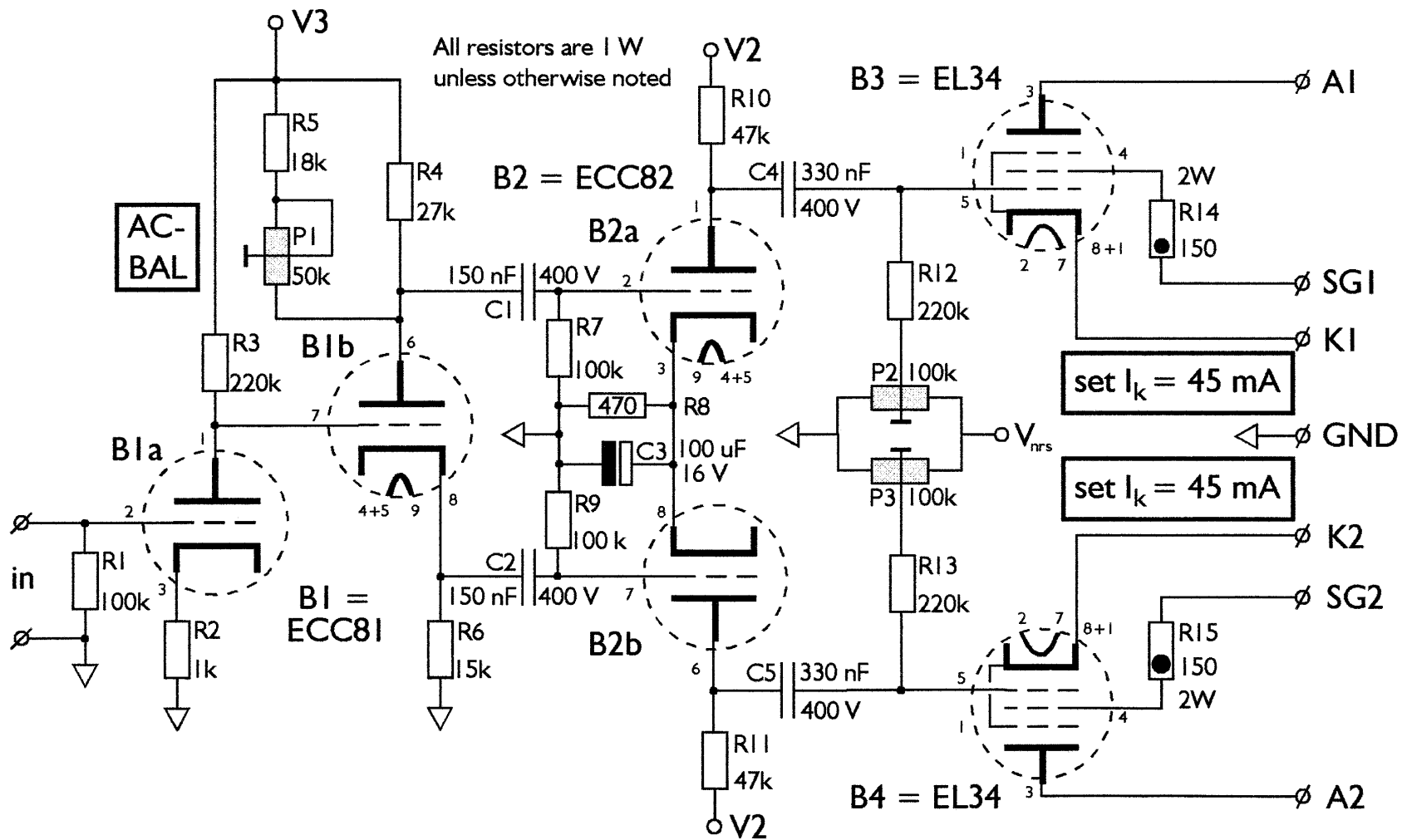

G-1328-2

FIGURE 2: Schematic of the standard amplifier circuit.

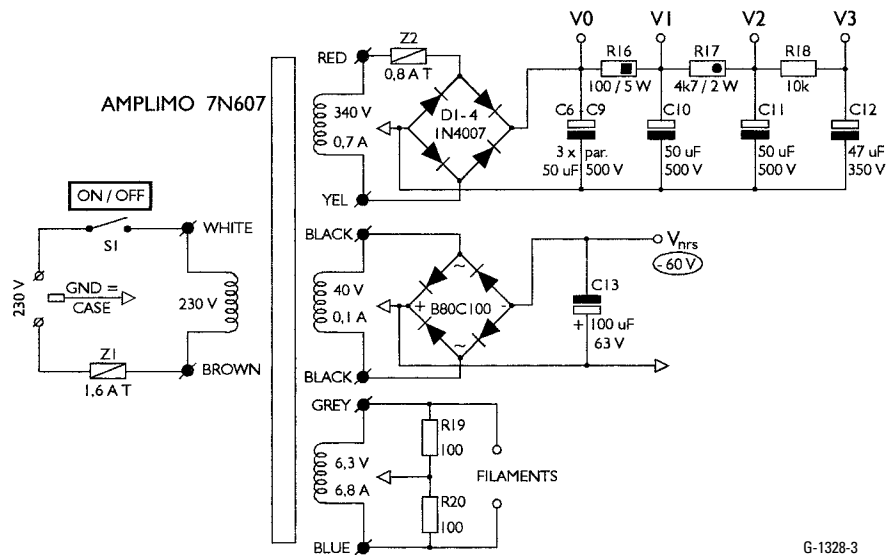

FIGURE 3: The power-supply circuit for the standard amplifier.

I constructed this amp hard-wired for easy experimentation on a 19" chassis, with transformers and tubes placed on top and the components hard-wired on the inside. I leave this all up to the knowledgeable DIYer.

## Tests for Optimal Adjustment

Two simple tests exist for correctly tuning phase splitter balance and the equality of the quiescent currents. Starting with the latter, suppose you have set the quiescent currents almost at their prescribed values. Now short the input of the amplifier, connect a loudspeaker, and listen to the humming of the amp with your ear very close to the speaker. To reduce this humming, turn only P3, for example, until the humming becomes minimal. When you measure both quiescent currents after this listening test, you might notice a small difference. However, these almost equal currents combined with their also nearly equal magnetic influence in the core of the OPT are optimally balanced now, as evidenced by the

low level of hum at the loudspeaker. Trimming with P1 for the correct balance of the phase-splitter output signals is also very simple. You need a 100 or 120Hz square-wave oscillator, an oscilloscope, and a suitable dummy load (8Ω) connected to the amplifier's output, replacing the speaker. Connect the square-wave oscillator to the input through a volume control set at its minimum. Connect the oscilloscope to the

amplifier's output (over the dummy load).

Now slowly turn up the volume of the square wave. Close to the maximum power output of the amplifier, you will see (and softly hear) that the rising and falling edges of the square wave will develop overshoots. Now turn P1 until the overshoots disappear. It is that simple to balance push-pull amplifiers for minimal harmonic distortion.

## Subjective Review

I used the EL34 power tubes for my research, because real pentodes were essential for those results. However, for my listening tests and subjective evaluation, I strongly prefer the SV6550C, with maximum output power close to 60W at a quiescent current of 75mA per tube. I know that the life span of the tubes is shortened thereby, but the sound quality is amazingly superior compared to lower current settings, so I don't care about the shorter tube life. I will now discuss the two new circuits, 5 and 7 in some detail.

In the Super-Pentode (circuit 5) the dynamic power capability and push are impressive, giving a lot of drive to the sound and a very acceptable open soundstage. It shows good bass control, is very suitable for dynamic large-power applications such as with musical instruments, and it behaves much better (as far as bass control and lower distortion go) than the standard pentode configuration of circuit 1.

However, circuit 7 is the absolute winner! Assume all the goodies, and you will meet them there. With the Super-Triode circuit, I am listening to a new generation of push-pull tube amplification. The details and spaciousness are extremely clean, quick, open, and well controlled, and all is heard in a detailed and large soundstage, where you clearly can hear a pin drop. The bass control is extremely tight and powerful. Measurements showed very low harmonic and intermodulation distortions. This, combined with the larger damping factor (DF = 2.5 with SV6550C at 75mA), explains the clean sound quality perceived. Try it; you will also be amazed.

To explain all these good qualities, let me introduce a new quantity: the Dynamic Damping Factor Distortion (DDFD). As you know, in a push-pull amplifier, the output transformer combines the currents of the two power tubes into one effective driving current. You encounter the lowest distortion when the combined tube characteristics result in new equidistant straight lines. The damping factor of the amplifier is in fact the slope of those lines.

However, the lines may be equidistant when crossing the load line of the OPT's primary, yet still have different slopes, indicating that the damping factor will change with the amount of output power. Calculations show that these slopes strongly depend on the value of the quiescent current. The greater this current, the more equal the slopes. This means that at larger quiescent currents, the damping factor will be more constant.



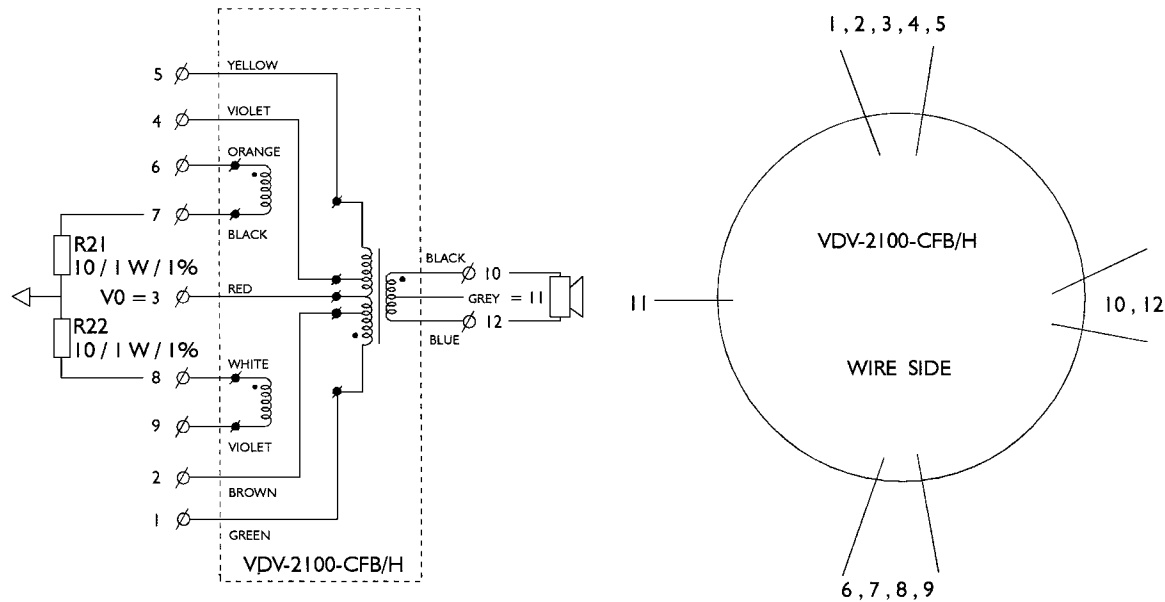

FIGURE 4: The colors and wire numbering of the specialist OPT.

Consequently the “distortion” in the output voltage due to a variable output impedance of the amplifier will now be minimal.

This theoretical concept of the DDFD clearly explains why large quiescent currents sound superior compared to small ones. The output impedance of the amp will then be constant and give constant control to the speaker-cone movement at all output power levels. A very quick-reacting amplifier is the good result. This explains my subjective preference for quiescent-current levels of 75mA with the SV6550C tubes.

## Choosing the OPT

Some remarks might be helpful in selecting the optimal toroidal “specialist” OPT. The amplifiers discussed here are optimally loaded when the primary impedance of the OPT is close to 3.3k $\Omega$ . My new “specialist” toroidal transformers provide a choice between two

primary impedances (2 or 4k $\Omega$ ), while the secondary impedance is 5 $\Omega$ . Which type is best suited for this application?

Suppose you select the VDV-2100-CFB or the VDV-2100-CFB/H. They differ only in maximum low-frequency power (100W and 70W, respectively). To give these transformers a primary impedance of 3.3k $\Omega$ , load them on the secondary side with a speaker of 8 $\Omega$ . When you select the VDV-4070-CFB (70W), with its primary impedance of 4k $\Omega$ , you should connect a 4 $\Omega$  loudspeaker to the secondary to get a primary impedance of 3.3k $\Omega$ . This means that the choice between the different OPTs is determined by the impedance of the loudspeaker you wish to use.

I performed all the measurements with the 2100-CFB/H, secondary loaded with 8 $\Omega$  with the EL34 pentodes. All my subjective evaluations were done with the 4070-CFB and SV6550C tetrodes, resulting in a damping factor of 2.5 in circuit 7 at

75mA quiescent current, and an effective -3dB power bandwidth from 14Hz-100kHz without any overall negative feedback.

Therefore my advice would be to select the 4070 version with two output tubes but with four output tubes (two-by-two paralleled) select the 2100 version. Then they will be optimally adapted to a generally acceptable 4 $\Omega$  loudspeaker loading, and this is how I intended to apply these new “specialist” toroidal transformers.

The names Super-Pentode and Super-Triode are registered by the author and subject to European Union and international copyright laws. Licensing inquiries concerning reproduction of and manufacture for trade sale should be directed to Menno van der Veen: e-mail: [mennovdv@noord.bart.nl](mailto:mennovdv@noord.bart.nl); fax: 31-38-453-3178. ♦

G-1328-4